

RF 2080 C/F



Calibrated Noise Source and Bandpass Filter

RF Associates

January 2010

RF 2080 C and RF2080 C/F

The RF 2080 is available in two versions. The RF2080 C contains a calibrated noise source. The RF2080 C/F contains both a calibrated noise source and a 20.1 MHz bandpass filter. The bandpass filter in the C/F model will reduce or eliminate interference to the Jove receiver caused by strong international broadcasting stations. Both models of the 2080 are to be installed between the antenna and the receiver, and require a +12 volt power supply.

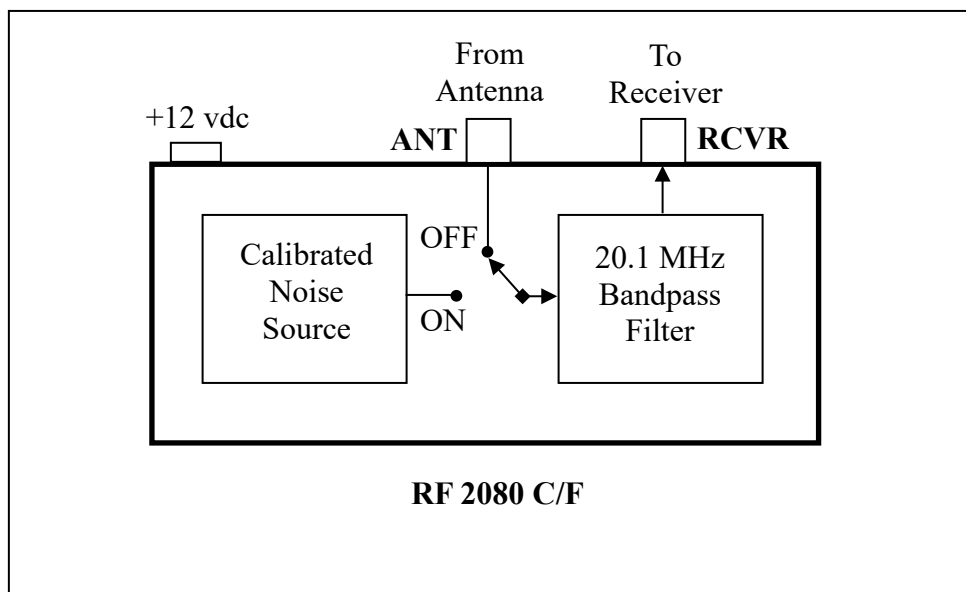

A single toggle switch controls power and also selects the source of the signal being routed to the receiver (either the antenna or the noise source). When the 2080 is OFF the antenna is connected to the receiver. When it is ON the calibrated noise source is connected to the receiver. In the C model the switch common is connected directly to the RCVR connector (a direct connection replaces the bandpass filter).

Calibrated Noise Source

RF2080C

The RF2080 noise source has been adjusted to a temperature of 25 thousand kelvins (referred to as 25Kk in the remainder of this manual) at 20.1 MHz. The noise source of the RF2080 C is accurate over several MHz. Since there is no bandpass filter in the RF2080 C, the 25Kk noise source is connected directly to the RCVR port when the power switch is turned ON.

RF2080CF

The RF2080 C/F includes a bandpass filter and the noise source signal passes thru this filter, which has a loss of approximately 1.5 dB. Therefore the temperature at the RCVR port is NOT 25Kk, but rather 17.7Kk (over a frequency range of 20.1 MHz +/-100 kHz).

Both models of the RF2080 are intended for use with the calibration wizard in Radio SkyPipe. When used with the Cal Wizard you should enter 25,000 as the noise source temperature – for either the RF2080 C or the RF2080 C/F. This is because the Cal Wizard reference point (known as the calibration point) is where the antenna connects to the RF2080 – the ANT port, (not where the RF2080 connects to the receiver). The fact that the output temperature of the RF2080 C/F box is 17.7Kk is important for non-standard uses (if you are not using the wizard to set up scaling in SkyPipe).

Uses

1. Receiving Site Evaluation. The RF2080 serves as a source of radio frequency noise which replicates the noise picked up by a shortwave receiver located at a very radio quiet listening site. The noise level of 25 thousand degrees was selected as typical of the level expected at such a quiet receiving site, where the only noise present is the so called galactic background – generated by relativistic electrons spiraling in the galactic magnetic field.

In reality there are usually additional sources of radio frequency noise – arcing power lines, computer hash, noise from light dimmers and fluorescent lights, aquarium heaters, electric motors, plasma TV sets, and just about any modern appliance which contains a microprocessor. The RF2080 can be used to evaluate how noisy your receiving site actually is. It also gives the user an idea of what “good clean noise” sounds like – a noise signal not contaminated with any of the “bad noise sources” listed above.

2. Receiving System Calibration. Most Jove observers use Radio SkyPipe software to plot and share their records of signals received from Jupiter, the Sun and the Galaxy. A SkyPipe record of Jupiter noise bursts is seen below.

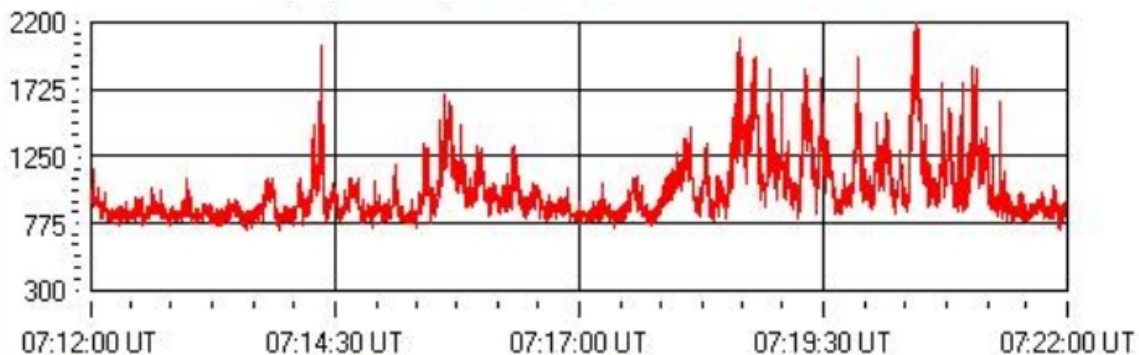

The horizontal axis is time, and the vertical axis is in SkyPipe Units (SPU). For this record the receiver and software gain controls were set so that the baseline runs around 800 units on the vertical scale with the strongest burst extending up to 2200 units.

The vertical axis of SkyPipe uses a numeric scale that can be set in the range of 0 – 32,000 when using the sound card input. The signal trace on the SkyPipe screen can be adjusted with the Jove receiver volume control and also the software volume control in Windows. By changing these gains, the trace can be moved up or down and compressed

or expanded. There is no absolute reference point. The SkyPipe vertical scale units are relative, unit-less, numbers. They are not engineering units like volts, watts, or degrees.

While the chart shows signals getting stronger or weaker as a function of time, it is difficult to make comparisons with records from other observers, since they may be using different gain settings, and their background noise level may be different. To obtain information about the absolute strength of the signals, we need to convert SkyPipe units (SPU) into engineering units with an absolute reference.

A calibrated noise source will transform our data from qualitative to quantitative. It will be used to convert SPU into engineering units.

Radio astronomers deal with very weak signals from the cosmos and they use special units to describe signal strength. One common unit is *antenna temperature*.

Antenna Temperature

A resistor connected to the antenna terminals of a receiver will generate a weak noise signal due to the random motion of free electrons within the resistor. If we heat the resistor up with a blowtorch (don't try this at home kids) the noise signal will increase in amplitude because of the increased thermal motion of those free electrons. The power of the noise signal transferred to the receiver is described by a simple equation.

$$P = kTB \quad (1)$$

Where:

P = power in watts

K = Boltzmann's Constant = $1.38 \times 10^{-23} \text{ jK}^{-1}$

B = receiver bandwidth in hertz

T = resistor temperature in kelvins

Equation 1 is strictly valid only if the resistor value is matched to the receiver antenna input impedance – for the Jove receiver this would require a 50 ohm resistor.

Let's calculate how much power is delivered to the receiver; if the resistor is at 25,000 kelvins, and the bandwidth of the receiver is 6 kHz. (6000 hertz).

Using equation (1),

$$P = (1.38 \times 10^{-23})(25 \times 10^3)(6 \times 10^3) = 2.1 \times 10^{-15} \text{ watts}$$

At a radio-quiet receiving site this is about the amount of power from the galactic background delivered to the receiver by the Jove antenna.

Because of this relationship between the noise signal generated by a resistor and the noise signal delivered from an antenna, it is convenient to describe the antenna signal in terms of antenna temperature. In theory we could replace the antenna with a resistor and vary

the temperature of the resistor until the noise power it produces matches the noise power from the cosmic radio source. When the noise power levels match we note the temperature of the resistor. This value of temperature is called *antenna temperature*.

Measuring Antenna Temperature

Fortunately, instead of a resistor and a blowtorch we can use a solid-state noise source that generates a known noise temperature. With the RF2080 we can rescale SkyPipe so that the vertical axis is in absolute units of antenna temperature.

Earlier we noted that SkyPipe units (SPU) are simply relative numbers generated in SkyPipe. Versions of SkyPipe earlier than 2.0 utilized a detection scheme that resulted in SPU being proportional to voltage. If the input voltage to SkyPipe doubled then the SPU would also double. Version 2.0 and later also include a power detection mode. In this mode SPU are proportional to the power, not voltage. If input power doubles, the SPU double. Since SPU are proportional to power they are also proportional to temperature – as related by equation 1. Using the new power detector mode in SkyPipe and the RF2080 it is possible to simply convert SPU into antenna temperature. Before going thru the step by step procedure to accomplish that conversion we need to consider a limitation to using this single step calibration.

Linear and Non-linear Operation

The receiver and sound card demonstrate linear operation over a certain range of signal strengths. This means that if the input doubles in strength then the output will double also. This relationship is seen in the plot below which relates input signal to output signal. The input could be the signal at the antenna terminals of the receiver, and the output could be the signal at the audio output of the receiver.

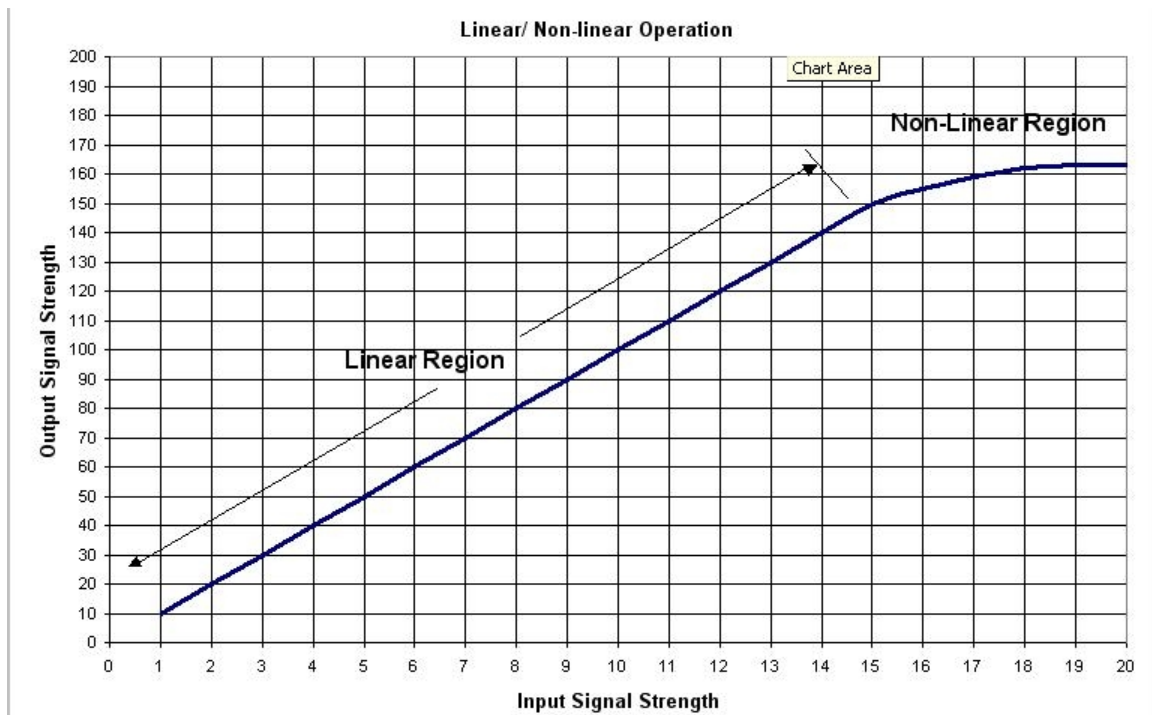

Up to an input level of about 15 units, we see that when the input doubles the output also doubles – that is, the slope of the line relating input and output remains constant (the line is straight). At higher input levels the output can no longer follow the input and begins to flatten out. This simply means that the receiver is reaching some maximum limit in terms of available output voltage and power. This region of compression is called non-linear. Eventually the output signal will not change at all as the input is increased – at this point the receiver is in saturation.

In the linear region – where the relation between the input and output is constant we can calibrate the system at a single point and use a simple equation to develop the proper vertical scale for all other signals. However, if signals are strong enough to drive the system into compression then the calibration is no longer valid.

Dynamic Range

The ratio of the maximum signal (just before going into compression), to the background signal level is the useful dynamic range of the system. With gain controls properly set the dynamic range of the Jove receiving system can exceed 25 dB (an increase of over 300 times in antenna temperature). This exceeds the range of most solar bursts. Setting the receiver and soundcard gain controls too high on the background will reduce the dynamic range. For the Jove RJ1.1 receiver, setting the gain control to the 12 o'clock position will insure a good dynamic range for solar observations.

Accuracy and the One-Step Calibrator

In an ideal world we would calibrate the receiving system performance at many different temperatures – well up into the compression region. However, in the interest of simplicity and cost we can use a one-step calibrator. If gains are set as recommended, this method should allow observers to measure antenna temperature of Jovian and solar bursts to a reasonable accuracy (+/- 1 dB) except in the compression region. Of course a multi-step calibrator such as the RF2050 can also be used (with the RF2050 you can use a single temperature and the cal wizard or use all 6 temperatures and derive a calibration equation which can be entered into SkyPipe).

A Common Reference for Antenna Temperature

Our goal is to scale the vertical axis of SkyPipe in terms of antenna temperature. In order to compare records with other observers the antenna temperature should be referenced to the antenna terminals (not to the receiver input, as different observers will have different losses due to different lengths of coax cable coming from the antenna). However, it would be inconvenient to take the RF2080 out into the field and perform our calibration at the antenna terminals. Instead we will locate the RF2080 next to the receiver with a short piece of coax cable connecting the two together. When given the proper cable loss information, SkyPipe will mathematically shift the temperature reference point from the ANT terminal of the RF2080 out to the antenna feedpoint.

Calibration Point

The ANT terminal of the RF2080 will be referred to as the *calibration point*. In order to reference the antenna temperature back out to the antenna terminals we must take into account all losses between the antenna terminals and the calibration point. The effect of cable loss is to reduce the power (temperature) reaching the receiver. Temperatures measured at the calibration point will always be lower than when referenced back to the antenna terminals. When using the calibration wizard in SkyPipe you will enter cable loss (or cable type and length) in order for the software to adjust for signal losses in the cable. After running the Cal Wizard the vertical scale of SkyPipe will be calibrated in antenna temperature referenced to the antenna terminals.

Jove Antenna Feedpoint

With a single dipole the feedpoint is where the coax attaches to the wires on either side of the center insulator. The Jove antenna uses coax cables connecting the two dipoles to a power combiner which is then connected to the receiver thru a single coax run. The Jove antenna terminal reference point is also right at the dipoles. We will account for all the loss occurring between the dipoles and the receiver, including the loss from the dipoles to the power combiner, the combiner itself, and in the cable running to the receiver. The Cal Wizard knows about the loss in the Jove antenna power combiner and the loss between the combiner and the dipole feedpoints. For the Jove dual dipole antenna all you have to do is enter the loss from the calibration point to the power combiner.

Alternatively, you can enter the type of coax and the length of cable and let the Cal Wizard estimate the cable loss.

Calibrating the Vertical Axis of SkyPipe

SkyPipe 2.0 and above include a utility to calculate cable losses, in-fact the whole process of calibrating and scaling the vertical axis in terms of antenna temperature (referenced to the antenna terminals) is incorporated in the program. While it is possible to use earlier versions of SkyPipe, and its equation editor function, the recommended method is with SkyPipe 2.0 and above. If you are using an older version of SkyPipe please upgrade to the latest version before continuing. (<http://radiosky.com>).

Install the RF2080 between the antenna and receiver (see detailed drawings for different installations on a following page). Use a short coax jumper cable between the RF2080 RCVR port and the receiver antenna terminal. Adjust the volume control on the Jove RJ1.1 receiver to the 12 o'clock position. Connect the receiver audio output to your computer soundcard input (use the *line* input if available). If you use the *mic* input be sure that mic boost is turned off. Launch SkyPipe and under Tools - Run the Calibration Wizard

Follow the prompts, entering antenna type, coax cable type, cable length, and calibrator temperature. SkyPipe will automatically scale the vertical axis in units of antenna temperature. **If you change the receiver gain, the calibration will become invalid. If you are using the RF2080 C/F you must leave it in line between the antenna and receiver (the system was calibrated with the RF2080 C/F filter in line and removing**

the unit will change the calibration). You may remove the RF2080 C from the line if you wish. After calibration is complete and if you leave the unit in-line, be sure to turn off the RF 2080. You can disconnect power from it completely, but be sure the power switch is off so that the antenna is connected to the receiver

A Post Calibration Test

After calibration is complete you will likely turn on the calibrator expecting to see the trace running at 25,000Kk. It may come as a surprise when the calibrator noise trace temperature is somewhat higher. What is going on? Remember that the temperature (at the ANT port of the RF2080) is referenced to the antenna terminals by SkyPipe. After the calibration is complete SkyPipe will also reference the noise source to the antenna terminals. For example, assume that you have 3 dB of loss between the calibration point and the antenna terminals. This means that the temperature at the antenna terminals is twice as high as at the calibration point (3dB is a factor of two). For this example the 25Kk noise source baseline will read 50Kk (as it should) on the SkyPipe display. If the loss between the calibration point and the antenna terminals had been zero, then the noise source trace would read 25Kk.

Measuring the Background Level

Tune the receiver between stations to a quiet spot on the dial and note the background temperature. If your receiving site is very radio quiet and your cable loss is very low you will see a background temperature on the order of 40 thousand degrees. If your cable loss is a dB or two and you see temperatures well in excess of say 200 thousand degrees then the site is quite noisy and this will impact your ability to receive weak to moderate Jupiter bursts. Solar bursts can be very strong and so they should be observable – even with this noise level. Significantly higher background temperatures suggest a very noisy site which may be completely unsuitable for Jupiter, and only marginal for the Sun.

Remedies for High Background Temperatures

Check for local sources of electrical noise by turning off appliances and circuit breakers. You may wish to run SkyPipe for 24 hours to see if any patterns emerge – perhaps the noise is only on at certain times – this information can help you to locate the source. Power line arcing can come and go – often it is bad during dry, windy, weather and clears up after a good rain. I have heard that in some places (never where I live) the electrical companies are cooperative and will work with you to eliminate the sources of arcing (usually loose hardware on the low voltage power distribution lines).

Configurations

The following diagram shows 3 common equipment configurations. Each indicates the cable section whose loss must be entered into the Cal Wizard. The “Jove Dual Dipole with Filter” diagram is intended for those who already use a special bandpass filter to protect the Jove receiver from overload. This is the same type filter that is now incorporated in the RF 2080 C/F. For each configuration you may enter cable attenuation (if you know it) or enter the cable type and length – either between the calibration point and the antenna feedpoint, or between the calibration point and the combiner output (Jove dual dipole).

Jove single dipole, or any single antenna such as a Yagi, or Moxon.

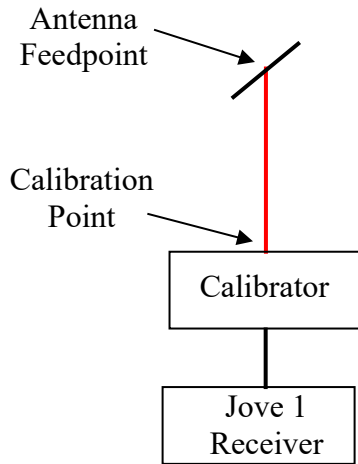

Jove Dual Dipole

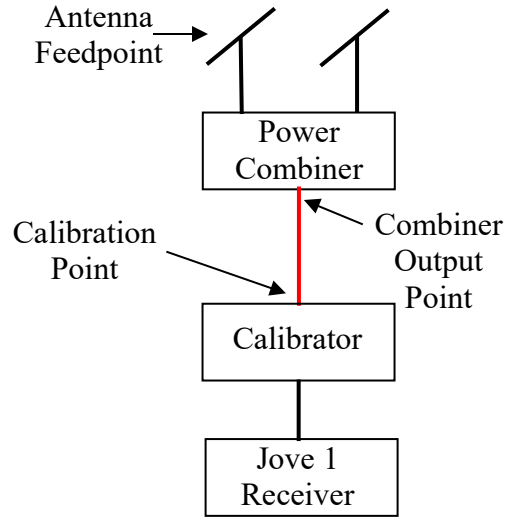

Jove Dual Dipole with Filter

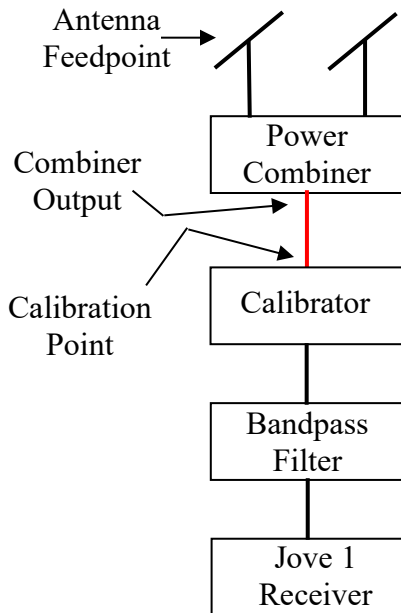

Other configurations are possible – for example a single antenna might be connected to a power splitter feeding multiple receivers. The calibrator should be installed between the antenna and specialty devices (power splitter, filters, etc). You must know cable type and length, or loss (in dB), from the calibration point to the antenna feedpoint. For reference, loss of the Jove power combiner is 0.5 dB, loss from Jove dipole feedpoint to the power combiner is 0.5 dB. At the Jove frequency of 20.1 MHz RG59 coax has a loss of 1.54dB /100' and RG6 coax has a loss of 0.84 dB /100'

Power Requirements

The RF2080 requires +12 to +15 volts DC at less than 50 ma. It uses an internal voltage regulator. The supplied power cord with a 2.1 mm plug has a black, red or white trace alone one wire. This wire should be connected to the + terminal of the power supply with the other wire connected to the negative terminal. A battery or regulated power supply is recommended. Many “wall wart” type modular supplies are poorly regulated and may include a switching circuit which can be very noisy electrically. Jameco (www.Jameco.com) sells the 162996 AC adapter which is a regulated 12 volt supply used with the Jove receiver. This unit is also suitable for use with the RF2080. It comes complete with DC power cord and plug which mates with the RF2080

NOTE – The RF2080 does not contain an internal fuse – current limiting must be provided in the external power supply circuit if desired.

Connection and Operation

Your noise source is equipped with two coaxial connectors (usually F type unless it is a special order with BNC connectors). One connector is labeled ANT and the other RCVR. The coaxial cable coming from the antenna should be connected to the ANT port and a short coaxial jumper cable should be connected between the RCVR port on the RF2080 and the antenna port on the receiver.

After connections are made it is a simple matter to calibrate. Turn ON the power switch and allow a short warm up period (30 seconds). With the switch is ON the antenna is disconnected and the noise source is turned ON and connected to the receiver. When the calibration is complete, turn OFF the power switch. If you forget to do this, the receiver will remain connected to the noise generator – and you may spend hours listening with no antenna connected. When calibration is complete it is not necessary to leave power connected to the calibrator.

RF Associates
Richard Flagg
rf@hawaii.rr.com

